

cod. 85193A Edition 04/2015

Index

GENERAL PRECAUTIONS	Pag. 2
ONP1 Series CORRECT USE OF INSTALLATION BRACKETS	Pag. 2
ONP1 Series CORRECT USE OF THE PCUR034 FLOATING CURSOR	Pag. 2
INSTRUCTIONS FOR ELECTRICAL INSTALLATION OF MAGNETOSTRICTIVE TRANSDUCERS	Pag. 3

GENERAL PRECAUTIONS

- The transducer must be installed away from sources of magnetic fields, both static and 50 Hz (electric motors, solenoids, etc.).
- The transducer connection cable must be wired separately from power cables and/or solenoid controls, drives, or remote switches.
- The line used for power supply must be dedicated to the transducers or must be drawn directly from the power terminals and as near as possible.
- When choosing a cursor for the ONP1 profile magnetostrictive transducer, remember that the transducer's cursor is a magnet. Therefore, if there are iron filings or small magnetic metal fragments in proximity of the transducer, avoid the use of sliding cursors, as there would be a risk of material accumulation on the cursor, creating problems for sliding. Use a floating cursor instead.

ONP1 SERIES – CORRECT USE OF INSTALLATION BRACKETS

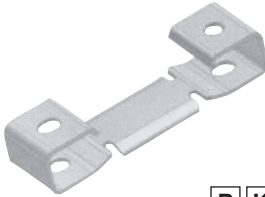

P K I T □ □ □

Brackets (2 brackets for every kit)	
Steel bracket, interaxis 42.5mm	590
Steel bracket, interaxis 50mm	591

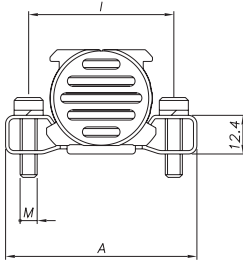
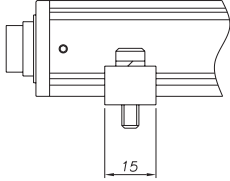
Brackets code	Interaxis (i)	Screw (V)	Dimension (A)
PKIT 590	42.5	M4	56
PKIT 591	50	M5	63.5

Use PKIT59x brackets (to be ordered separately) to correctly install the ONP1 magnetostrictive transducer.

Choose the best model based on the material, on the attachment holes interaxis and on the dimension of the screws included in the package. Each package has two brackets. We recommend to install one bracket every 250-300 mm.

To guarantee the correct electrical insulation of the transducer from the machine, always assemble the brackets using the plastic washers provided in the package as shown in the fig. a and fig. b.

To prevent damages to the isolating bushes and to the brackets, tighten the fastening screws with a maximum torque of 1.1 Nm.

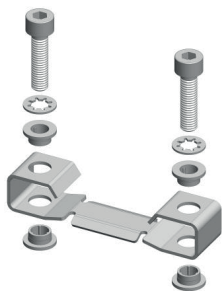

fig. a

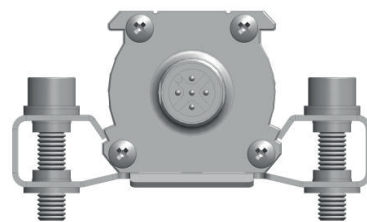
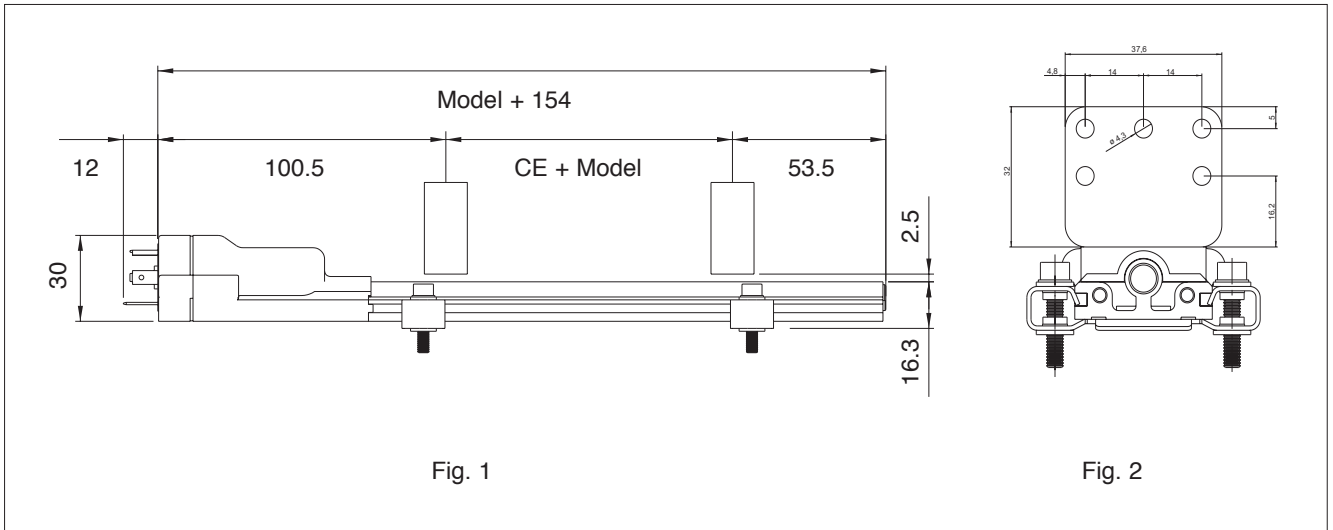

fig. b

ONP1 SERIES – CORRECT USE OF THE PCUR034 FLOATING CURSOR



Under standard conditions (Fig. 1), the PCUR034 cursor must be installed on a support made of non-magnetic material (such as brass, aluminium, or AISI316 stainless steel).

The installation kit, consisting of two screws, two nuts, and two washers (all made of brass), is included in the package. The cursor (Fig. 2) must be installed with maximum attention to horizontal alignment with the transducer axis (maximum tolerance is ± 2 mm), as well as to the distance from the transducer surface from 2 to 5 mm.

If there is no alternative to a magnetic support, it's necessary to prevent the support from changing the magnetic field generated by the cursor, because this could cause problems with the correct measurement of the cursor position.

For this reason, a non-magnetic spacer must be added between the cursor and the magnetic support (Fig. 3 - Sol. 1).

The recommended spacer thickness is 15 mm. If the application does not permit the installation of a non-magnetic spacer, it's possible to install the cursor directly on the magnetic support, being careful not to let the support make direct contact with the part of the cursor containing the magnet (Fig. 3 - Sol. 2).

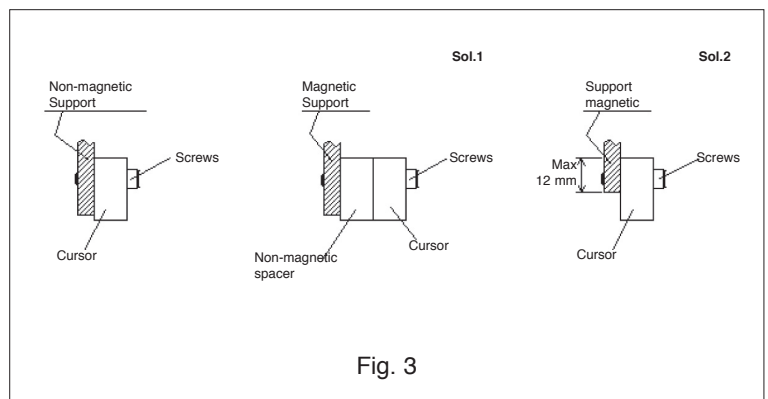

INSTRUCTIONS FOR ELECTRICAL INSTALLATION OF MAGNETOSTRICTIVE TRANSDUCERS

The magnetostrictive transducers conform to the following directives:

- Electromagnetic Compatibility EMC 2004/108/CE
- RoHS 2002/95/CE

For a correct electrical installation of the transducers, refer to the "Manual for Electrical Installation of Magnetostrictives." The manual and certificates of conformity can be downloaded from the website www.gefran.com.

